

Side Rail Butt System Purlins

Side Rail Butt System suitable for buildings with single bays or more.

Types of Cladding

The loads shown relate directly to metal cladding and allowance for its weight has been made. Figures shown are for horizontal wind pressure and assume 1 row of side rail supports at mid span up to 6 metres and 2 rows for larger spans.

For suction multiply values by a factor of 0.8.

Asbestos Cladding

Spans up to 5.5 metres – 1 row of side rail supports at mid span.

Spans over 5.5 metres – 2 rows of side rail supports.

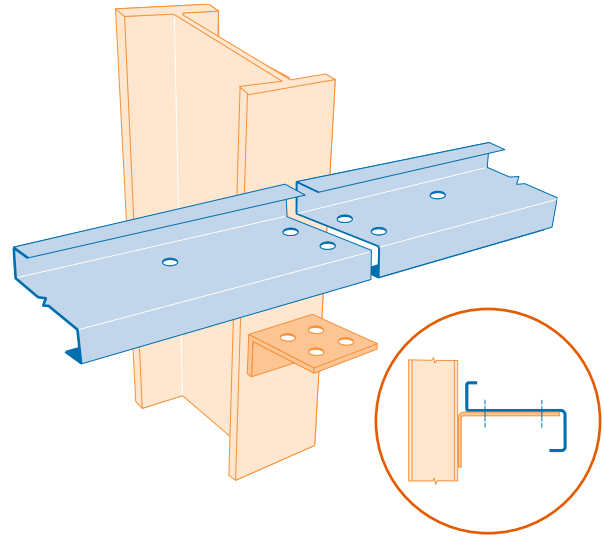

Span Metres	Section	U.D.L. kN	(Purlin Centres (mm))					Allowable Loads kN/m ²			
			1000	1200	1375	1500	1675	1800	2000	2500	
3.5	12115	10.53	3.01	2.51	2.19	2.00	1.80	1.67	1.50	1.20	
	12116	11.32	3.23	2.70	2.35	2.16	1.93	1.80	1.62	1.29	
	14015	11.14	3.18	2.65	2.31	2.12	1.90	1.77	1.59	1.27	
	14016	12.00	3.43	2.86	2.49	2.29	2.05	1.90	1.71	1.37	
	14018	12.74	3.64	3.03	2.65	2.43	2.17	2.02	1.82	1.46	
	14020	13.96	3.99	3.32	2.90	2.66	2.38	2.22	1.99	1.60	
	17715	13.56	3.87	3.23	2.82	2.58	2.31	2.15	1.94	1.55	
	17716	14.50	4.14	3.45	3.01	2.76	2.47	2.30	2.07	1.66	
	17718	16.10	4.60	3.83	3.35	3.07	2.75	2.56	2.30	1.84	
	17720	17.67	5.05	4.21	3.67	3.37	3.01	2.80	2.52	2.02	
	20018	20.80	5.94	4.95	4.32	3.96	3.54	3.30	2.97	2.38	
	20020	23.82	6.81	5.67	4.95	4.54	4.06	3.78	3.40	2.72	
20025	27.32	7.81	6.50	5.68	5.2	4.66	4.34	3.90	3.12		
4.0	12115	8.80	2.20	1.83	1.60	1.47	1.31	1.22	1.10	0.88	
	12116	9.45	2.36	1.97	1.72	1.58	1.41	1.31	1.18	0.95	
	14015	9.36	2.34	1.95	1.70	1.56	1.40	1.30	1.17	0.94	
	14016	10.08	2.52	2.10	1.83	1.68	1.50	1.40	1.26	1.01	
	14018	10.72	2.68	2.23	1.95	1.79	1.60	1.49	1.34	1.07	
	14020	11.73	2.93	2.44	2.13	1.96	1.75	1.63	1.46	1.17	
	17715	11.51	2.88	2.40	2.09	1.92	1.72	1.60	1.44	1.15	
	17716	12.29	3.07	2.56	2.23	2.05	1.83	1.71	1.54	1.23	
	17718	13.66	3.42	2.85	2.48	2.28	2.04	1.90	1.71	1.37	
	17720	15.00	3.75	3.13	2.73	2.50	2.24	2.08	1.88	1.50	
	20018	17.66	4.42	3.68	3.20	2.94	2.63	2.45	2.21	1.77	
	20020	20.21	5.05	4.21	3.68	3.37	3.01	2.81	2.53	2.02	
20025	23.17	5.79	4.83	4.20	3.86	3.46	3.22	2.90	2.32		
4.5	12115	6.96	1.55	1.29	1.12	1.03	0.92	0.86	0.77	0.62	
	12116	7.47	1.66	1.38	1.21	1.11	0.99	0.92	0.83	0.66	
	14015	8.20	1.82	1.52	1.33	1.21	1.09	1.01	0.91	0.73	
	14016	8.83	1.96	1.64	1.43	1.31	1.17	1.09	0.98	0.78	
	14018	9.37	2.08	1.74	1.51	1.39	1.24	1.16	1.04	0.83	
	14020	10.26	2.28	1.90	1.66	1.52	1.36	1.27	1.14	0.91	
	17715	10.19	2.26	1.89	1.65	1.51	1.35	1.26	1.13	0.91	
	17716	10.89	2.42	2.02	1.76	1.61	1.44	1.34	1.21	0.97	
	17718	12.09	2.69	2.24	1.95	1.79	1.60	1.49	1.34	1.07	
	17720	13.27	2.95	2.46	2.14	1.97	1.76	1.64	1.47	1.18	
	20018	15.24	3.39	2.82	2.46	2.26	2.02	1.88	1.69	1.35	
	20020	17.46	3.88	3.23	2.82	2.59	2.32	2.16	1.94	1.55	
20025	20.00	4.44	3.70	3.23	2.96	2.65	2.47	2.22	1.78		

Purlins Side Rail Butt System

Span Metres	Section	U.D.L. kN	(Purlin Centres (mm))					Allowable Loads kN/m ²			
			1000	1200	1375	1500	1675	1800	2000	2500	
5.0	12115	6.20	1.24	1.03	0.90	0.83	0.74	0.69	0.62	0.50	
	12116	6.65	1.33	1.11	0.97	0.89	0.79	0.74	0.67	0.53	
	14015	7.34	1.47	1.22	1.07	0.98	0.88	0.82	0.73	0.59	
	14016	7.90	1.58	1.32	1.15	1.05	0.94	0.88	0.79	0.63	
	14018	8.39	1.68	1.40	1.22	1.12	1.00	0.93	0.84	0.67	
	14020	9.19	1.84	1.53	1.34	1.23	1.10	1.02	0.92	0.74	
	17715	9.21	1.84	1.54	1.34	1.23	1.10	1.02	0.92	0.74	
	17716	9.83	1.97	1.64	1.43	1.31	1.17	1.09	0.98	0.79	
	17718	10.92	2.18	1.82	1.59	1.46	1.30	1.21	1.09	0.87	
	17720	12.00	2.40	2.00	1.75	1.60	1.43	1.33	1.20	0.96	
	20018	13.60	2.72	2.27	1.98	1.81	1.62	1.51	1.36	1.09	
	20020	15.58	3.12	2.60	2.27	2.08	1.86	1.73	1.56	1.25	
	20025	17.84	3.57	2.97	2.60	2.38	2.13	1.98	1.78	1.43	
5.5	14015	6.45	1.17	0.98	0.85	0.78	0.70	0.65	0.59	0.47	
	14016	6.94	1.26	1.05	0.92	0.84	0.75	0.70	0.63	0.50	
	14018	7.37	1.34	1.12	0.97	0.89	0.80	0.74	0.67	0.54	
	14020	8.08	1.47	1.22	1.07	0.98	0.88	0.82	0.73	0.59	
	17715	8.42	1.53	1.28	1.11	1.02	0.91	0.85	0.77	0.61	
	17716	9.00	1.64	1.36	1.19	1.09	0.98	0.91	0.82	0.65	
	17718	10.00	1.82	1.52	1.32	1.21	1.09	1.01	0.91	0.73	
	17720	10.96	1.99	1.66	1.45	1.33	1.19	1.11	1.00	0.80	
	20018	12.38	2.25	1.88	1.64	1.50	1.34	1.25	1.13	0.90	
	20020	14.18	2.58	2.15	1.88	1.72	1.54	1.43	1.29	1.03	
20025	15.93	2.90	2.41	2.10	1.93	1.73	1.61	1.45	1.16		
6.0	14015	5.50	0.92	0.76	0.67	0.61	0.55	0.51	0.46	0.37	
	14016	5.92	0.99	0.82	0.72	0.66	0.59	0.55	0.49	0.39	
	14018	6.29	1.05	0.87	0.76	0.70	0.63	0.58	0.52	0.42	
	14020	6.89	1.15	0.96	0.84	0.77	0.69	0.64	0.57	0.46	
	17715	7.56	1.26	1.05	0.92	0.84	0.75	0.70	0.63	0.50	
	17716	8.07	1.35	1.12	0.98	0.90	0.80	0.75	0.67	0.54	
	17718	8.97	1.50	1.25	1.09	1.00	0.89	0.83	0.75	0.60	
	17720	9.84	1.64	1.37	1.19	1.09	0.98	0.91	0.82	0.66	
	20018	11.21	1.87	1.56	1.36	1.25	1.11	1.04	0.93	0.75	
	20020	12.98	2.16	1.80	1.57	1.44	1.29	1.20	1.08	0.87	
	20025	14.55	2.43	2.02	1.76	1.62	1.45	1.35	1.21	0.97	
6.5	17715	6.75	1.04	0.87	0.76	0.69	0.62	0.58	0.52	0.42	
	17716	7.20	1.11	0.92	0.81	0.74	0.66	0.62	0.55	0.44	
	17718	8.00	1.23	1.03	0.90	0.82	0.73	0.68	0.62	0.49	
	17720	8.79	1.35	1.13	0.98	0.90	0.81	0.75	0.68	0.54	
	20018	10.47	1.61	1.34	1.18	1.07	0.96	0.89	0.81	0.64	
	20020	11.99	1.84	1.54	1.34	1.23	1.10	1.02	0.92	0.74	
	20025	13.57	2.09	1.74	1.52	1.39	1.25	1.16	1.04	0.84	
7.0	20018	9.67	1.38	1.15	1.00	0.92	0.82	0.77	0.69	0.55	
	20020	11.01	1.57	1.31	1.14	1.05	0.94	0.87	0.79	0.63	
	20025	12.58	1.80	1.50	1.30	1.20	1.08	1.00	0.90	0.72	
7.5	20020	10.33	1.38	1.15	1.00	0.92	0.82	0.77	0.69	0.55	
	20025	11.72	1.56	1.30	1.13	1.04	0.93	0.87	0.78	0.63	
8.0	20025	10.48	1.31	1.09	0.95	0.87	0.78	0.73	0.66	0.52	
8.5	20025	8.75	1.03	0.86	0.75	0.69	0.62	0.57	0.51	0.41	